

# SPECK® BADU® Eco Touch VS

## INSTALLATION AND OPERATION MANUAL

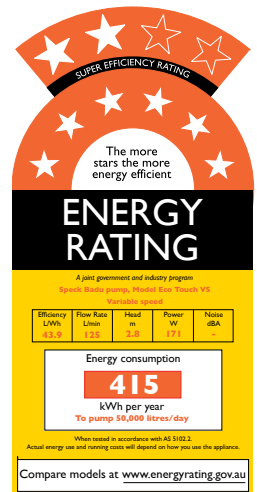

# SPECK® BADU® Eco Touch VS

## INSTALLATION AND OPERATION MANUAL

1.0	INTRODUCTION .....	3
2.0	SAFETY INFORMATION .....	3
3.0	TECHNICAL SPECIFICATIONS .....	4
4.0	INSTALLATION .....	4
5.0	OPERATION .....	5
6.0	SERVICE AND MAINTENANCE .....	8
7.0	TROUBLESHOOTING .....	9
8.0	WARRANTY .....	10

## 1.0 INTRODUCTION

Congratulations on your choice of a **Badu Eco Touch VS** 8-Star Energy Rated Pump for your pool or spa. When used correctly, this German engineered pump will save you money on energy costs and keep your pool sparkling clean all year round.

Your **Badu Eco Touch VS** pump is powered by a patented revolutionary permanent magnet brushless DC motor controlled by advanced logic electronics to provide cooler, quieter operation at a fraction of the cost of a standard pump.

While your **Badu Eco Touch VS** comes with factory preset speeds, the pump controller can be configured to run the pump to suit the size of your pool and your particular needs. Please see **Section 5.3 The Badu Eco Touch VS (variable speed) Custom Speed Setting**.



Please read these instructions in their entirety prior to using your new pump.

### 1.2 8-STAR ENERGY SAVINGS AT YOUR FINGERTIPS

We recommend using a normal pump speed of 1450rpm and this is the speed that achieves an 8 star energy efficiency rating. It should be noted however that this speed may not be practicable in all pool applications dependent on many external factors such as types and age of filters, the hydraulic circuit of the pool pipe work and return lines, the size of the chlorinator used etc. If the performance requires some boosting then you can adjust the speed to gain an optimum condition for your particular pool setup. Please see Section 5.3 **The Badu Eco Touch VS (variable speed) Custom Speed Setting**.

## 2.0 SAFETY INFORMATION

### 2.1 IMPORTANT SAFETY INSTRUCTIONS, READ AND FOLLOW ALL INSTRUCTIONS. SAVE ALL INSTRUCTIONS.

- 2.1.1  **WARNING:** Hazardous Suction. Pump suction is hazardous and can trap hair and body parts resulting in severe injury or death. Do not block filtration suction lines with any part of your body. If someone becomes trapped, immediately turn the pump off.
- 2.1.2  **WARNING:** Two suction inlets (minimum 500mm apart) must be provided into every pump to avoid suction entrapment. If a suction cover is broken, missing or loose, do not operate the swimming pool or spa.
- 2.1.3 A qualified technician should carry out the pump installation.
- 2.1.4 Always wear protective clothing and gloves when handling adhesives.
- 2.1.5 The pump must be installed and operated in accordance with national wiring rules.
- 2.1.6 Children should be supervised to ensure they do not play with the appliance.
- 2.1.7 If the power supply cord is damaged, it must be replaced by the manufacturer, its service agent or similarly qualified persons in order to avoid a hazard.
- 2.1.8 This appliance is not intended to be used by persons (including children) with reduced physical, sensory or mental capabilities, or lack of experience and knowledge, unless they have been given supervision or instruction concerning use of the appliance by a person responsible for their safety.

- 2.1.9 The pump power must be supplied through a residual current device (RCD) having a rated residual operating current not exceeding 30mA.
- 2.1.10 Routinely check the pump basket, skimmer and entire pool system to maximise the life of the pool equipment and personal safety. Always turn the pump off before carrying out checks and maintenance.
- 2.1.11 **DO NOT** remove any safety alert labels on the pump such as **DANGER, WARNING** or **CAUTION**. Keep safety labels in good condition and replace missing or damaged labels.

## 3.0 TECHNICAL SPECIFICATIONS

Model	Motor model	Rated power	Max/min head [m]	Inlet Conn.	Outlet Conn.	RPM	Power Input	Power Output kW	AMPS	Weight	Max Water Temp
Eco Touch VS	Fasco Motor 807B8BQTC-B22BL	975	15/1	50	40			110	8.6	11	35

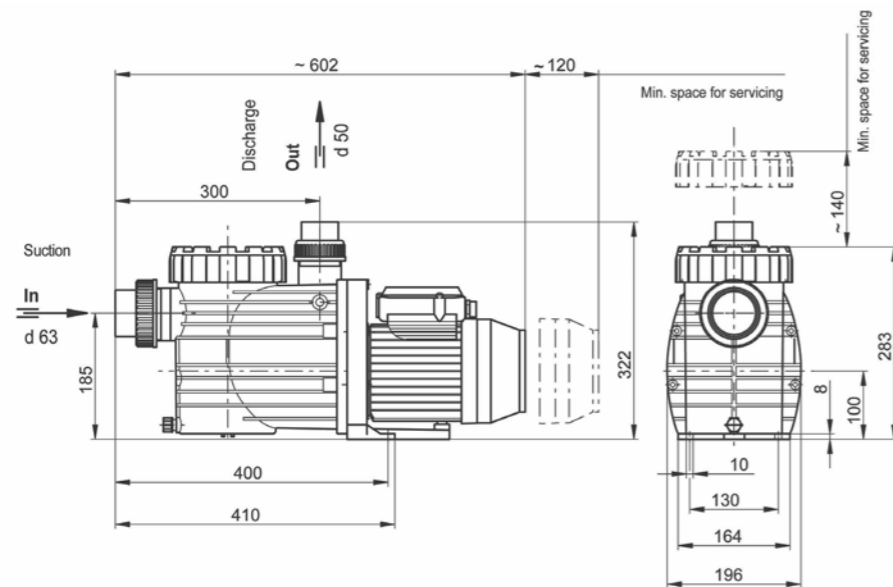

## 4.0 INSTALLATION

### 4.1 LOCATION

- 4.1.1 Locate the pump as close to the pool as practical and in accordance with any relevant regulations or recommendations.
- 4.1.2 The pump must be installed in a dry and well-ventilated position protected from the elements.
- 4.1.3 A clearance of 250mm is required behind the motor for ease of removal and ventilation.
- 4.1.4 The pump must be installed horizontally up to 3 metres maximum below or 1.5 metres maximum above the pool water level.
- 4.1.5 **DO NOT** store or use gasoline or other flammable gases or liquids in the vicinity of this pump. **DO NOT** store pool chemicals near the pump.
- 4.1.6 Flooding or moisture in the motor voids warranty. Ensure the pump is elevated and kept dry.

## 4.2 PLUMBING CONNECTION

- 4.2.1 The piping should be as direct and free from turns or bends as possible as elbows and other fittings can greatly increase friction losses.
- 4.2.2 If the pump is located below water level, isolation valves must be installed on both sides of the pump to prevent the back flow of pool water during any routine or required servicing.
- 4.2.3 Use PVC fittings for all connections. A 50mm (2") suction / inlet Union is provided and a 40mm (1.5") discharge / outlet Union is provided. The suction and discharge pipes must not be smaller in diameter than the pump fittings (otherwise flow rates may be affected).
- 4.2.4 Use plumbing Cleaner Primer to clean and prepare the pipe ends and Union Sockets. Place the Union Collars over the pipe ends. Using plumbing Solvent Cement glue the Union Sockets to the pipe ends. Allow at least 24 hours for any adhesive to dry thoroughly before starting the pump.
- 4.2.5 Ensure that the o-rings are fitted to the Union Sockets and apply a suitable o-ring lubricant if required. Also check that the pump basket lid o-ring is sufficiently lubricated.
- 4.2.6 Connect the Unions to the pump by tightening the Union Collars by hand (do not use any tools to tighten the collars as damage may occur).
- 4.2.7 Suction and discharge lines should be independently supported at a point near the pump to avoid strains being placed on the pump.

## 4.3 ELECTRICAL CONNECTION

- 4.3.1 **Badu Eco Touch VS** pumps are suitable for connection to a nominal 230V AC 50hz power supply.
- 4.3.2 The motor is equipped with a flexible cable and 3-pin plug. If a power outlet is not available within 2 meters of the pump, a 3-pin power point in a safe dry place will need to be provided by an electrician.
- 4.3.3 The pump power must be supplied through a residual current device (RCD) having a rated residual operating current not exceeding 30mA.
- 4.3.4 Extension cords are unsafe around pools and must be avoided.

## 5.0 OPERATION

### 5.1 GENERAL START UP GUIDE

- 5.1.1 **CAUTION:** Never run the pump without water. Running the pump "dry" for any length of time can cause severe damage to both the pump and the motor and will void the warranty.
- 5.1.2 If it is a new pool installation, make sure all piping is clear of construction debris and has been properly pressure tested. Special care must be taken to ensure no small pebbles are ingested into the pump as this voids the warranty.
- 5.1.3 The filter should be checked for proper installation, verifying that all connections are secure according to the manufacturer's recommendations.

- 5.1.4 Depending on the location of the pump, do one of the following:
- a) If the pump is located below the water level of the pool, open the filter pressure valve to prime the pump with water.
  - b) If the pump is located above the water level of the pool, remove the lid and fill the basket with water before starting the pump.
- 5.1.5 Prior to replacing the lid, check for debris around the lid o-ring seat. Debris around the lid o-ring seat will make it difficult to prime the pump and may damage the o-ring.
- 5.1.6 Hand-tighten the lid collar to make an air tight seal (do not use any tools to tighten the collar as damage may occur).
- 5.1.7 Make sure all valves are open and the unions are tight. Turn on the pump, the pump will take a short time to prime and then deliver at full rate. No further priming should be required.
- 5.1.8 If prime is not established within approximately two minutes (as evidenced by a strong flow of water from the outlet) switch off the pump and repeat the procedure above (5.1.4 through 5.1.7).
- 5.1.9 If bubbles persist under the lid there is a leak in the suction connections or the lid is not sealed properly, switch off the pump and repeat the procedure above (5.1.5 through 5.1.7).

## 5.2 ONGOING OPERATION

5.2.1 The **Badu Eco Touch VS** (variable speed) pump comes factory preset with 3 speeds:

Button	RPM	Application
1	1900*	Slightly boosted speed for filtration and chlorination.
2	2410	Gentle spa jet action and filtration at times of heavier pool use.
3	2850	Vacuums, backwashing and operation of spa jets or water features.

\*NOTE: To achieve maximum 8-star energy efficiency, this setting can be adjusted down to 1450 rpm – see Section 5.3 below.

- 5.2.2 The **Badu Eco Touch VS** (variable speed) pump will automatically start at high speed for five (5) minutes to ensure it primes completely. The pump will take a short time to prime and then deliver at full rate. No further priming should be required.
- 5.2.3 After 5 minutes the pump can be set to the desired / required speed. In future, at power up, the pump will run for 5 mins on high speed and then automatically default to the setting selected prior to the pump powering down.
- 5.2.4 To select a default speed simply press 1, 2 or 3. The corresponding LED will indicate which speed has been selected.

## 5.3 BADU ECO TOUCH VS (VARIABLE SPEED) CUSTOM SPEED SETTING

- 5.3.1 The **Badu Eco Touch VS** (variable speed) pump is a full variable speed pump with each speed setting being able to be programmed to any customised speed. To program a custom speed, carry out the following steps:
- 5.3.2 Select one of the speed settings 1, 2 or 3 to adjust.

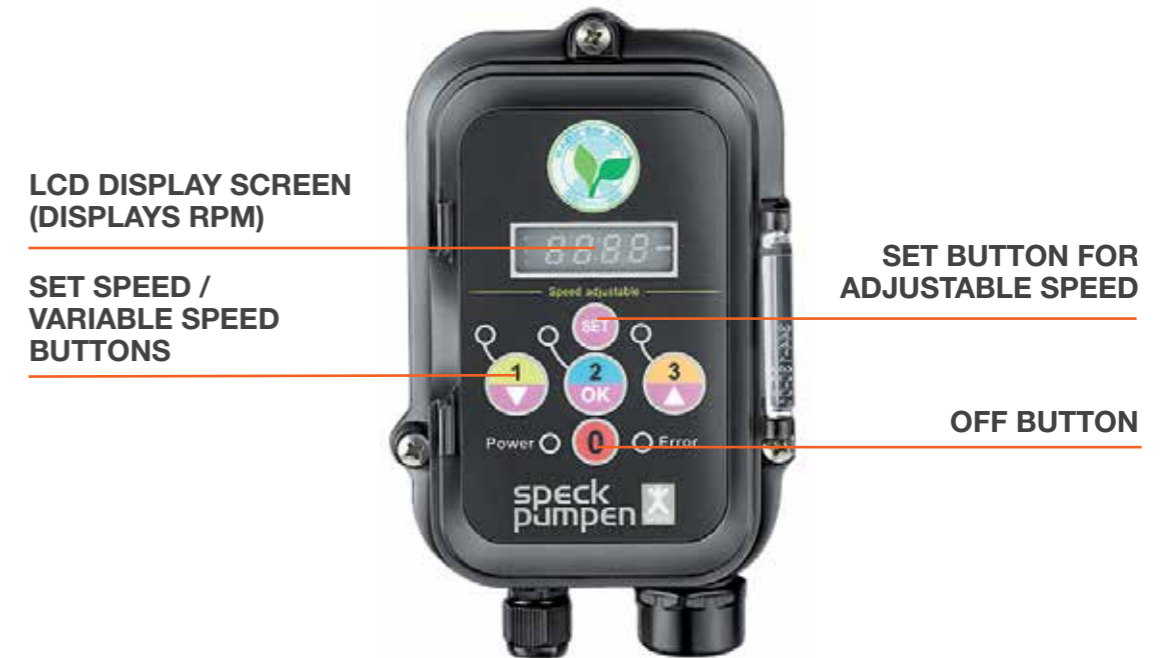

- 5.3.3 Hold the Set button down for three (3) seconds until the LED Display Screen flashes.
- 5.3.4 Press button 1(▼) to decrease speed. Press button 3(▲) to increase speed. Speed adjustments will be in 50 RPM increments. Press button 2 (OK) to save the new speed and return to normal operation.
- 5.3.5 If you do not want to save the setting press the stop button or simply wait for 30 seconds.
- 5.3.6 Holding the Set button for 15 seconds will revert settings back to factory default settings outlined in section 5.2.1. The pump will turn off when this has been done.

## 6.0 SERVICE AND MAINTENANCE

- 6.1.1 To achieve a maximum potential life expectancy from the pump ensure the following steps are taken:
- 6.1.2 **Empty the skimmer basket regularly.** The regularity will vary from pool to pool, for example:
- Where you may have lots of leaves and debris you should empty the basket twice or more for each operating cycle, particularly when using a suction type cleaner.
  - Where you may have minimal leaves and debris the basket may only require checking weekly.
  - Always remove children's toys or balls from the pool when not in use.
- 6.1.3 **Check for leakages.** Carry out weekly inspections, for example:
- Around the pump, filter, chlorinator and heater (where fitted) where water can leak from all or some of these components.
  - If water is present whether you can see the source of the leak or not, then contact your serviceman immediately. This may reduce the possibility of major pump damage.
- 6.1.4 Inspect and empty the pump lint basket at least weekly.
- Turn pump OFF at the mains power supply.
  - Close all valves where fitted, to prevent water loss through pump.
  - Remove clear plastic screw-down lid off the pump.
  - Remove yellow plastic basket and empty any contents. If a sock or filter has been fitted, inspect it for holes and replace if necessary.
  - Inspect the chamber housing of the basket, ensure no debris, pebbles or leaves have fallen in whilst removing the basket, remove all foreign material.
  - Return the yellow basket into the chamber, there are two sets of guides for the basket to sit in. Ensure the basket is correctly seated to avoid any damage to the pump.
  - Lubricate the o-ring. The o-ring can be located on top of the chamber where the lid screws on, use a silicone lubricant which is available from your pool shop or serviceman (Do NOT use petroleum gel or axle grease as this will damage the o-ring).
  - Replace the screw-down lid firmly by hand only.
  - Re-open any valves where fitted that were closed in step (b) above.
  - Operate the pump.** It is essential that the pump be operated after carrying out the above procedure, this will purge any air from the system. Start the pump and wait until the lint basket is full of water. Then where fitted, open air bleed fitting on the filter to expel air. Once the stream of water emerges all air is gone and the air bleed valve can be closed.
- 6.1.5 **Dirty Filters.** Restricted water flow from a dirty filter can cause the pump to overwork thus shortening its lifespan. Please follow the filter manufacturer's guidelines for the method and frequency of cleaning.

- 6.1.6 **Noisy Pump.** As with all mechanical devices, if more noise than usual is heard coming from the pump, notify the pool retailer or service technician where you purchased the product. A noise can indicate a fault and the longer this is left unattended the risk of increased damage can occur resulting in an expensive repair or replacement.
- 6.1.7 **Pebblecrete Pools.** All pebblecrete or similar pools should initially be fitted with a sock in either the skimmer basket or in the pump lint basket to prevent damage to the pump as a result of loose stones making their way through the system. Should a sock not be installed, any subsequent damage caused by loose pebble entering the pump impeller will void the warranty.

## 7.0 TROUBLESHOOTING

- 7.1.1  **WARNING:** Your pump must be serviced by a professional service technician qualified in pool / spa installation. The following procedures must be followed exactly. Improper installation and / or operation can create dangerous electrical hazards, which can cause high voltage to run through the electrical system. This can cause property damage, serious personal injury and / or death. Improper installation and / or operation will void the warranty.

### 7.2 GENERAL PUMP TROUBLESHOOTING

Problem	Possible Cause	Corrective Action
1. Pump will not prime	A. Suction air leak	Make sure see-through lid and o-rings are clean and properly positioned. Hand tighten see-through lid. Tighten all pipes and fittings on suction side of pump. Be sure water in pool is high enough to flow through skimmer box.
	B. No water in pump	Make sure strainer tank is full of water and free of air.
	C. Closed valves or blocked lines	Open all valves in system. Clean skimmer and strainer tank. Open pump and check for clogging of impeller.
	D. Low voltage to motor	Check voltage at motor. If low, pump will not come up to speed
2. Motor does not turn	A. No power to motor	Check that all power switches are on. Be sure fuse or circuit breaker in the power box is properly set.
	B. Pump jammed	With power off, turn shaft. It should spin freely. If not, repair by an authorised repairer is required.
3. Low flow	A. Dirty Filter	Backwash filter or clean cartridges.
	B. Suction leak	See problem 1 above.

## 7.3 BADU ECO TOUCH VS (VARIABLE SPEED) PUMP TROUBLESHOOTING

7.3.1 The **Badu Eco Touch VS** (variable speed) Pump has an LED Error light on the control panel which flashes to indicate a warning. If the Error light is flashing, pay attention to the number of flashes between intervals then shut the pump down. For instance, if a “Low Voltage” situation occurs, the Error LED will blink twice, then turn off, then blink twice. This sequence is repeated until the condition is cleared.

Blinks	Fault	Cause
1	Micro controller failure	Micro controller is continually rebooting.
2	Mains under voltage	The mains voltage has dropped below 180 volts AC running. Note: If this fault is active the controller will reboot automatically after voltage comes above 209 volts AC for at least 6 seconds.
3	Temperature	Over temperature (100 degrees Celsius) Under temperature (-20 degrees Celsius)
4	Over current trip	Over current protection has tripped.
5	Mains over voltage	The mains voltage has risen above 269 volts AC.
6	Output shaft seized	Motor failed to start. Motor was stopped.
7	Self check	One or more of the self-tests failed either at start up or while running.
8	Motor fault	One or more of the phases has become disconnected
10	Other fault	Any fault not covered by the other codes. Presently no faults should trigger this.
None	EEPROM load failure	Checksum failed while loading EEPROM to memory

## 8.0 WARRANTY

The Australian Competition and Consumer Act (2010) (Cth) (including the Australian Consumer Law) guarantee certain conditions, warranties and undertakings, and give you other legal rights in relation to the quality and fitness for purpose of consumer goods sold in Australia (Applicable Laws). Our goods come with guarantees that cannot be excluded under the Australian Consumer Law. You are entitled to a replacement or refund for a major failure and for compensation for any reasonable foreseeable loss or damage. You are also entitled to have the goods repaired or replaced if the goods fail to be of acceptable quality and the failure does not amount to a major failure.

This express warranty provided by Continental Water Systems Pty Ltd (CWS) is in addition to any other rights and remedies imposed by Applicable Laws that cannot be excluded. Nothing in this warranty is to be interpreted as excluding, restricting or modifying any Applicable Laws which cannot be excluded, restricted or modified.

Any express warranty is limited to the length of time specified in the ‘Terms of Express Warranty’ referred to below, being from the date of purchase and is subject to the conditions set out in the express warranty. In no event shall CWS be accountable for consequential loss or damage resulting from the breach of any express warranties.

Under Applicable Laws you may have different or additional legal rights, including longer warranty periods, which vary from jurisdiction to jurisdiction. Some jurisdictions do not allow certain limitations on how long an implied warranty lasts, so the limitations in this warranty may not apply to you.

### 8.1 TERMS OF EXPRESS WARRANTY

Your Speck pool pump carries a manufacturer’s warranty of two (2) years on the motor and five (5) years on wet end components including casing, diffuser, gland housing, impellor and mechanical seal subject to the following terms:

- 8.1.1 CWS warrants to the original purchaser that all Speck pool pumps manufactured by CWS are free from defects in workmanship and materials of construction at the time of dispatch from CWS premises.
- 8.1.2 The warranty on ancillary components not manufactured by CWS will be limited to the warranty extended to CWS by the manufacturer of the said ancillary components.
- 8.1.3 The replacement of consumable items, including lids and baskets is not covered by this warranty.

### 8.2 EXCLUSIONS

To the maximum extent permitted by Applicable Laws, the warranty will not apply under any of the following circumstances:

- 8.2.1 The Purchaser is in breach of the terms and conditions of sale.
- 8.2.2 The product was used for a purpose or under conditions other than what it was intended for.
- 8.2.3 The product was repaired, modified or altered by any person other than a CWS Authorised Representatives.
- 8.2.4 The product was not installed, maintained and/or operated in complete compliance with the installation and operating instructions and any instructions provided by CWS.
- 8.2.5 The product was operated under adverse conditions including, but not limited to, use with water exceeding 35°C, hot operating enclosures with poor ventilation, fluctuating power supplies, water pressure greater than 250kpa, or lack of protection from the weather.
- 8.2.6 Normal wear and tear or deterioration associated with the age or use of the product.
- 8.2.7 The product was damaged by foreign debris entering via suction pool cleaners, refer to equipment installation instructions.
- 8.2.8 The product was damaged by weather and other environmental conditions including but not limited to storm, flood, and/or heat wave damage.
- 8.2.9 Failure of the mechanical seal due to insufficient water flow caused by any blockage or ingress of foreign matter of any kind whatsoever.
- 8.2.10 Damage to the product caused by the addition of chemicals, salt filter media or any other thing through the skimmer box.
- 8.2.11 Failures or any defects in component, part or operating function of the product, which is in the opinion of CWS the result from misuse, negligence, rebuilds or modification, incorrect installation by persons that are not CWS Authorised Representatives.

---

## 8.3 LIMITATIONS

Except to the extent permitted by Applicable Laws, breach of a condition or warranty, shall be limited to replacing or acquiring the same equipment (or any part thereof) or the services supplied.

The maximum liability incurred by CWS shall not exceed in any case the contract price for the equipment or the product parts claimed to be defective. Further, CWS shall not be liable for any loss, damage or delay directly or indirectly caused by any malfunction of or defect of or failure of the equipment other than as expressly stated in this warranty.

Subject to Applicable Laws, the repair or replacement of the product or part of the product is the absolute limit of CWS liability under this express warranty.

## 8.4 WARRANTY CLAIMS

If you consider that the product which you have purchased is not of acceptable quality, has a latent defect or is otherwise not compliant with the warranties, conditions, undertakings and legal rights you have under Applicable Laws you can make a claim under this warranty by contacting:

**Continental Water Systems Pty Ltd**  
5 Anvil Road, SEVEN HILLS NSW 2147  
**Email:** sales@continentalwater.com.au

All onsite service work is subject to a service call charge which will be quoted and which must be accepted by the customer before any or all work will be carried out.

Any equipment requiring warranty repair (alleged) must be returned to the place of purchase and or nearest CWS approved stockist (prepaid), as soon as the purchaser becomes aware of any fault. Neither CWS nor the approved CWS stockist shall be responsible for any goods damaged in transit. If the equipment is found to be defective after examination it will be repaired or replaced free of charge and returned freight collect. If the equipment is not defective and outside of warranty all repair or replacement costs will be charged to the purchaser or their representative and returned freight collect.

All Warranty claims must be accompanied by the proof of purchase, alleged defect and any appropriate documentation (Historical and maintenance records).

## 8.5 CUSTOMER WARRANTY INFORMATION

8.5.1 Please complete the information below at time of installation and retain in the event you need to file a warranty claim.

<b>Model Number</b>	
<b>Pump Serial Number</b>	
<b>Purchase Date</b>	
<b>Purchased From</b>	
<b>Installation Date</b>	
<b>Installer</b>	

---

# **SPECK® BADU® Eco Touch VS**

CONTINENTAL WATER SYSTEMS | P.O. Box 297 Seven Hills 1730 | Ph: 1300 166 253 | ABN: 71 050 287 735